



GC15S-9 / GC18S-9 / GC20SC-9  
GC20S-9 / GC25S-9 / GC30S-9 / GC33S-9  
GC35S-9 / GC35S-9 BCS / GC45S-9 / GC45S-9 BCS / GC55C-9 / GC55C-9 BCS

## 9 SERIES FORKLIFTS

Internal Combustion Cushion Tire Forklifts

3,000 lb. to 12,000 lb. Capacity



*Changing the Game*

The World Class 9 Series Cushion Trucks from Doosan

[www.doosanlift.com](http://www.doosanlift.com)

# Packed with Features

Focused on Value



**"We run our Doosans hard and they don't let us down"**

### PROVEN RELIABLE

- Industry proven industrial engines
- Heavy duty powertrain
  - o Double gear reduction drive axle
  - o Heavy duty taper roller bearing steer axle



**"Of all the forklifts we have tried, Doosan products are by far the easiest to own"**

### LOW COST OF OWNERSHIP

- Fewer recommended service intervals
- 5-Year, 10,000 hr. brake warranty
- Doosan's Assurance Warranty
- Industry leading financing

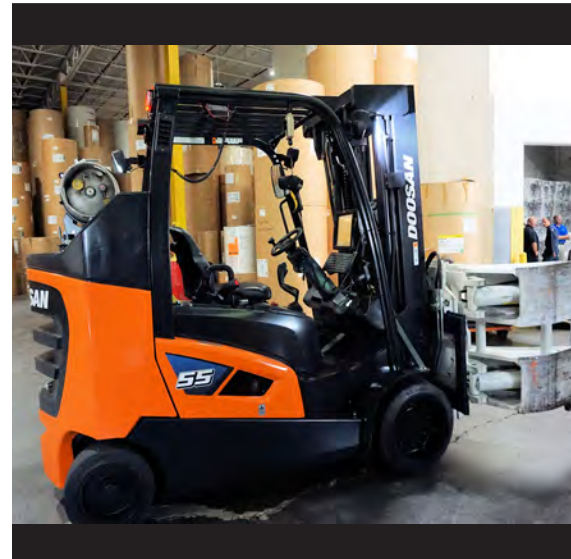

**"Finally, a truck that does it all. Safety, comfort and performance. We love Doosan!"**

### INCREASED PRODUCTIVITY

- Excellent forward visibility
- Built with operator comfort in mind
- Agile in confined spaces
- Heavy duty cooling system



The new 9 Series from Doosan continues our tradition of delivering heavy duty performance with low cost of ownership.



### Improved Operator Comfort

- Operator leg room is increased by 20%
- Inching & brake pedal effort reduced by 70%
- Thick rubber floor mat reduces heat & noise
- Smaller steering wheel means less fatigue
- Fully adjustable suspension seat, standard on all models



### Advanced Safety Features

- Operator Safety System (OSS)
- Improved visibility through the mast
- Electronic parking brake
- Safety lights, strobes, alarm & mirrors
- Rear grab bar with horn button
- Orange seat belt



### Ergonomic Layout

- Conveniently positioned hydraulic levers
- Lower dash profile for improved forward view
- Lower step-up into operator's compartment
- Three-point entry system
- Pedals and seat designed for operator comfort



# Product Features Overview

## Modern Design, Intelligent Engineering

### Operator Compartment

Designed for comfort, the operator compartment allows users to find their optimum driving position.

### Ergonomically Placed Hydraulic Controls

Strategically placed in the right position to reduce shoulder fatigue for operators of any size.

### Operator Sensing System (OSS)

The OSS shuts down travel and lift functions when the operator leaves the seat.

### Counterweight & Cooling

The sleek new counterweight design allows better airflow to maximize cooling capacity.

### Engine Cover

The redesigned engine cover opens at a wide angle to provide excellent accessibility to the main compartment.

### Hydrostatic Steer Axle

Doosan's heavy duty steer axle provides smooth steering control and durability.

### Integrated Junction Box

Fuses and relays are neatly organized to simplify maintenance and troubleshooting.



Power, performance, driving comfort, durability, and outstanding fuel efficiency are just a few reasons to choose 'The 9 Series'.



### High Visibility Mast

The new mast design is reinforced and allows improved forward visibility.

### Ergonomic Steering Column

The telescopic steering column allows the operator to properly adjust for comfort. The steering wheel is sized for reduced operator fatigue.

### New Instrument Panel

The full sized LED instrument panel is conveniently located to remain in full view of the operator at all times.

### Rigid, Heavy Duty Drive Axle

Durable cast iron housing with reinforced mast mounts assure stability and long life.

### OCDB (Oil-cooled Disc Brakes)

The OCDB significantly reduce maintenance and repair costs while increasing stopping power.

### Maintenance-friendly Design

The side cover and floor plates provide easy access to the powertrain making maintenance a breeze.

### Fewer Recommended Service Intervals

Superior components and intelligent engineering allow these trucks to operate longer between recommended service intervals. This means increased run time and lower cost of ownership.

# Advanced Safety Features

## Safety Assured



Doosan understands the importance you place on safety. That's why the 9 Series offers a large array of standard safety features.

### Operator Sensing System - (OSS)

Should the operator not be seated, OSS automatically prohibits operations such as:

- Truck movement
- Lift, lower, tilt functions
- Seat belt warning light reminds the operator to fasten belt
- Directional lever must be in the neutral position to start the truck

### Electronic Parking Brake

Conveniently located next to the hydraulic control levers.

### Improved Visibility

The 9 series LP forklifts have hydraulic hoses and mast chains strategically placed for wide forward visibility. This is crucial for safe operation and increased productivity.

### 'Operator Optimized' Display Location

Display remains in full view of the operator even while driving or using the hydraulic control levers.

### Rear Grab Handle w/ Horn

Allows the operator to sound the horn and still remain in control when traveling in reverse. The grab bar is placed so that the operator's hand is always inside the safety guard.

### Safety Strobe, Alarm & Rear View Mirrors

Safety strobe, back-up alarm and side mirrors come standard on all models.

# Productivity

## Reliable Durability

### 5-Year, 10,000 Hr. Oil Cooled Disc Brake Warranty

- Discs are submerged in oil, keeping them cool and limiting wear
- 100% of friction material is used for superior stopping power
- OCDB are more easily serviced in the field than traditional brakes
- System is sealed for maximum protection against contamination



### Optimized Cooling System

- Larger radiator offers increased cooling capacity
- Structural design of the radiator fan maximizes airflow
- Larger hydraulic reservoir helps dissipate engine heat
- Greater cooling capacity equals increased versatility

### Heavy Duty Hydrostatic Steer Axle

- No mechanical connections between steering wheel and steer axle
- Low effort steering for operator comfort and reduced fatigue
- Quick steering response for increased maneuverability and safety
- Grease fittings on king pin and steer linkage for easy maintenance
- Shock absorbing steer axle bushings extend service life

### Superior Components

- Larger king pins and tapered roller bearings for a stronger axle
- Angled rollers are stronger against side forces
- Tapered roller bearings have an inner race, eliminating wear on the king pin



Doosan



Others



Doosan Industrial Vehicle America Corp.

# Excellent Serviceability

Easily Serviced Less Often





Daily safety and routine maintenance checks are easy thanks to logical placement of commonly checked items. Doosan maximizes run time.

### Easy to access service areas

- The engine cover opens extra wide to offer great access
- Spring lock enabled for safety and convenience
- Performing general maintenance is easy
- Toolless floor plates provide easy access

### Well-positioned components make service a breeze

- Air filter service display on dashboard for fast servicing
- Easily accessed maintenance-related components
- Centralized fuse & relay access

### Quick access to key elements

- Battery
- Air filter
- Oil filters
- Dipsticks & level indicators

### Well-placed LED display keeps operators informed

- Continuous monitoring of all vital systems
- Service error codes on dashboard display
- Easy to read large LED display



## Application Versatility

### Solutions to Fit Your Various Needs

Special application packages make these machines a perfect fit in almost any environment.

#### Heavy Duty Cooling Package

Short Shuttle & Long Run Applications  
Attachment use application

Features Include:

- Increased Cooling Capacity Radiator
- High Speed Fan

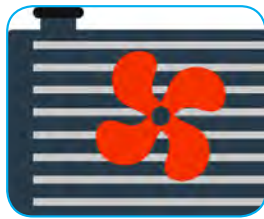

#### Beverage/Warehouse Package

Short Shuttle & Long Run Applications  
Features Include:

- Increased Cooling Capacity Radiator
- High Speed Fan
- Bottler's Tilt (forward : 10"/ back : 6")
- Louvered Side Panel



#### Fiber/Paper/Lumber Package

Dirty or Dusty Applications

Features Include:

- Increased Cooling Capacity Radiator
- High Speed Fan
- Louvered Side Panel
- Radiator Screen
- Belly Protection & Engine Guard
- Pre-cleaner



#### Rail Road/Warehouse Package

Short Shuttle & Long Run Applications

Features Include:

- Increased Cooling Capacity Radiator
- High Speed Fan
- Louvered Side Panel
- Box Car Special
- Swing Out & Tilt Down LP Cradle



# Dedicated Support

## Doosan Adds Value

### Easy to Purchase

Over 165 Authorized Doosan Dealership locations with trained experts ready to support you.

### Easy to Lease

Doosan Financial Services offers world class lease and finance options.

### Easy to Own

Doosan's Assurance Warranty is one of the most comprehensive warranties in the business. Doosan's proven lower cost of ownership makes the new 9 Series trucks the natural choice when it is time for your next purchase.

### Parts Availability

- Extensive domestic parts operation
- Industry-leading first-pass fill rates
- Dedicated experts to assist you
- Peace of mind



**Doosan's Industry-Leading Parts Operation**



**Doosan's North American Headquarters**

## By the Numbers

### Doosan Forklifts Lower Overall Cost of Ownership

Here are some of the key elements in which Doosan Forklifts offer significant savings over time.

#### Robust Steer Axle Components

Heavier components and superior engineering merge to create a steer axle assembly which should last on average 5 years. This could save you over \$2,500 in repair costs.

#### Oil Cooled Disc Brakes

With a 5-year or 10,000 hour warranty, our braking system is superior in every way. Much easier to service in the field than traditional shoe brakes, our OCDBs could save you more than \$2,250 in repair costs alone.

#### Fewer Scheduled Preventative Maintenance Jobs

Doosan saves you money by lengthening the periods between scheduled maintenance. With Doosan's PM schedule, you could see a \$1,200 savings within the first 5 years.



# BCS-9

## Doosan Forklifts Box Car Special

Space constraints? Consider Doosan's BCS models. With a shorter counterweight, these trucks easily navigate congested work spaces.

BCS units are heavily used in industry segments such as railroads, airports, paper mills, manufacturing, warehousing and freight transport.



### DIVAC North American Dealer Network

Doosan Industrial Vehicle America Corp. (DIVAC) provides high quality support through its extensive dealer network. No matter where you are located, Doosan-trained professionals are always ready to help you.

- North American Dealer Locations
- \* North American Headquarters

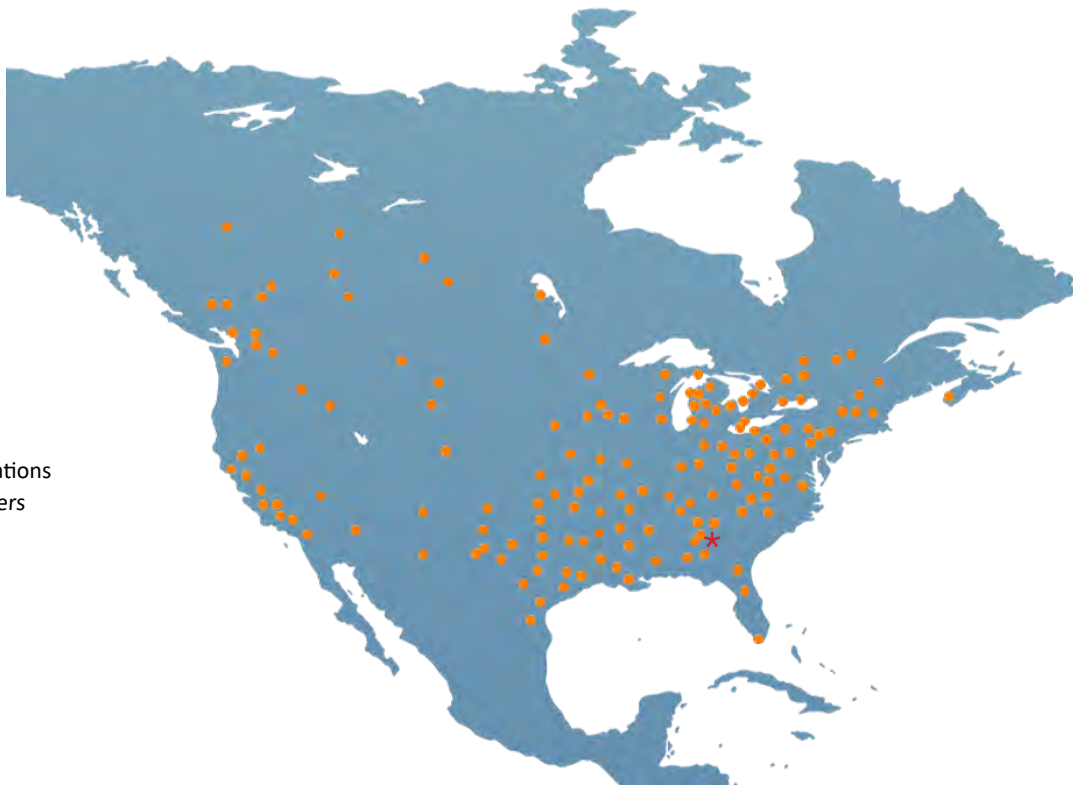

### Worldwide Service Network

Doosan Industrial Vehicle provides quality support, sales and service on a world-wide scale. Factory trained experts share their experience and knowledge with various Doosan subsidiaries around the world. This means you always have options and assistance, no matter where you are.



- Production Subsidiary
- Sales Subsidiary



**Doosan Industrial Vehicle America Corp.**

2475 Mill Center Parkway, Suite #400  
 Buford, GA 30518  
 P) 678-745-2200 F) 678-745-2250  
 Web) www.doosanlift.com

PSCGCS-9V1

Authorized Dealer



GC15S-9 / GC18S-9 / GC20SC-9

GC20S-9 / GC25S-9 / GC30S-9 / GC33S-9

GC35S-9 / GC35S-9 BCS / GC45S-9 / GC45S-9 BCS / GC55C-9 / GC55C-9 BCS



## 9 SERIES FORKLIFTS

Internal Combustion Cushion Tire Forklifts

3,000 lb. to 12,000 lb. Capacity



# TECHNICAL DATA

Characteristics	1.1	Manufacturer			Doosan	Doosan	Doosan	
	1.2	Model Designation			<b>GC15S-9</b>	<b>GC18S-9</b>	<b>GC20SC-9</b>	
	1.3	Drive: Diesel, Gasoline, LP			LP	LP	LP	
	1.4	Operator Type: Seated			Seated	Seated	Seated	
	1.5	Load Capacity	Q	lb(kg)	3,000 (1,340)	3,500 (1,560)	4,000(1,785)	
	1.6	Load Center	c	in(mm)	24 (610)	24 (610)	24(610)	
	1.8	Load Distance: Center of Driveaxle to Fork	x	in(mm)	15.5 (394)	15.5 (394)	15.7(399)	
	1.9	Wheelbase	y	in(mm)	50.6 (1,285)	50.6 (1,285)	50.6(1,285)	
	Weight	2.1	Service Weight			lb(kg)	6,038 (2,739)	6,460 (2,930)
2.2		Axle Loading, Loaded Front/Rear			lb(kg)	7,529/1,462 (3,415/663)	8,393/1,504 (3,807/682)	9,292/1,545 (4,215/701)
2.3		Axle Loading, UnLoaded Front/Rear			lb(kg)	2,266/3,770 (1,028/1,710)	2,266/4,191 (1,028/1,901)	2,266/4,634 (1,028/2,102)
Tires	3.1	Tires: Pneumatic (P), Cushion (C)				C	C	C
	3.2	Tire size, Front				18 x 6 x 12.12	18 x 6 x 12.12	18 x 6 x 12.12
	3.3	Tire size, Rear				14 x 5 x 10	14 x 5 x 10	14 x 5 x 10
	3.5	Wheels, number Front/Rear				2/2	2/2	2/2
	3.6	Tread, Front	b11	in(mm)		31.0 (786)	31.0 (786)	31.0 (786)
	3.7	Tread, Rear	b12	in(mm)		32.0 (814)	32.0 (814)	32.0 (814)
Dimensions	4.1	Tilt of Mast Forward/Backward	a/b	°		6/8	6/8	6/8
	4.2	Height, Mast lowered	h1	in(mm)		78.0 (1,980)	78.0 (1,980)	78.0 (1,980)
	4.3	Free Lift	h2	in(mm)		5.1 (130)	5.1 (130)	5.3 (135)
	4.4	Max Fork Height	h3	in(mm)		118.0 (3,000)	118.0 (3,000)	118.0 (3,000)
	4.5	Height, Mast Extended	h4	in(mm)		159.3 (4,045)	159.3 (4,045)	159.4 (4,050)
	4.7	Height of Overhead Guard(Cabin)	h6	in(mm)		81.0 (2,060)	81.0 (2,060)	81.0 (2,060)
	4.8	Height of Seat	h7	in(mm)		41.5 (1,055)	41.5 (1,055)	41.5 (1,055)
	4.19	Overall Length	l1	in(mm)		124.1 (3,152)	124.9 (3,173)	127.1 (3,228)
	4.20	Length to Forkface	l2	in(mm)		82.8 (2,102)	83.6 (2,123)	85.7 (2,178)
	4.21	Overall Width	b1/b2	in(mm)		37.0 (940)	37.0 (940)	37.0 (940)
	4.22	Fork Dimensions	s/e/l	in (mm)		1.4x4x41 (35x100x1,050)	1.4x4x41 (35x100x1,050)	1.4x4x41 (35x100x1,050)
	4.23	Fork Carriage ISO 2328, Class/Type A,B				II/A	II/A	II/A
	4.24	Fork Carriage Width	b3	in(mm)		37.0 (940)	37.0 (940)	37.0 (940)
	4.31	Ground Clearance, Loaded (Below Mast)	m1	in(mm)		3.0 (75)	3.0 (75)	3.0 (75)
	4.32	Ground Clearance, Center of Wheelbase	m2	in(mm)		4.1 (105)	4.1 (105)	4.1 (105)
	4.34.1	Aisle Width for Pallets L=48" x W=40"	Ast	in(mm)		127.6 (3,242)	129.3 (3,284)	130.5 (3,314)
4.35	Turning Radius	Wa	in(mm)		71.9 (1,826)	73.5 (1,867)	74.4 (1,891)	
4.36	Internal Turning Radius	b13	in(mm)		23.8 (605)	23.8 (605)	23.8 (605)	
Performance Data	5.1	Travel Speed, Loaded/UnLoaded		mph (km/h)		11.1/11.1 (17.8/17.8)	11.1/11.1 (17.8/17.8)	11.1/11.1 (17.8/17.8)
	5.2	Lift Speed, Loaded/UnLoaded		fpm (m/s)		126/130 (0.64/0.66)	124/130 (0.63/0.66)	122/130 (0.62/0.66)
	5.3	Lowering Speed, Loaded/UnLoaded		fpm (m/s)		100.4/98.4 (0.51/0.5)	100.4/98.4 (0.51/0.5)	100.4/98.4 (0.51/0.5)
	5.5	Drawbar pull, Loaded/UnLoaded(@ 1mph)		lb(N)		3,196 (14,225)	3,196 (14,225)	3,196 (14,225)
	5.6	Max. Drawbar pull, Loaded/UnLoaded		lb(N)		3,636 (16,180)	3,636 (16,180)	3,636 (16,180)
	5.7	Gradeability, Loaded/UnLoaded(@ 1mph)		%		38.5/69.4	33.0/60.1	31.0/56.1
	5.8	Max. Gradeability, Loaded/UnLoaded		%		46.8/90.1	39.8/76.0	36.5/70.3
	5.10	Service Brake				Foot/Hydraulic	Foot/Hydraulic	Foot/Hydraulic
Combustion Engine	7.1	Engine Manufacturer/Type				PSI/4G63	PSI/4G63	PSI/4G63
	7.2	Engine Power		hp(kW)		50.6 (37.7)	50.6 (37.7)	50.6 (37.7)
	7.3	Rated Speed		min-1		2,450	2,450	2,450
	7.3.1	Torque at 1/min		ft•lbs (N•m)		110@1,800 (148.7@1,800)	110@1,800 (148.7@1,800)	110@1,800 (148.7@1,800)
	7.4	Number of Cylinders/Displacement		-/cc(-/cm3)		4/1,997	4/1,997	4/1,997
7.10	Battery Voltage/Normal Capacity		V/Ah		12/45	12/45	12/45	
Oth.	10.1	Operating Pressure for Attachments		psi(bar)		2,553 (176)	2,553 (176)	2,553 (176)
	10.2	Oil Volume for Attachments		gpm(l/min)		13.2 (50)	13.2 (50)	13.2 (50)

Note: Specification values quoted in this spec sheet have been rounded. Performance may vary due to operating conditions. Products and specifications are subject to improvement and change without prior notice.

Characteristics	1.1	Doosan	Doosan	Doosan	Doosan	Doosan
	1.2	<b>GC20S-9</b>	<b>GC25S-9</b>	<b>GC30S-9</b>	<b>GC33S-9</b>	<b>GC35S-9</b>
	1.3	LP	LP	LP	LP	LP
	1.4	Seated	Seated	Seated	Seated	Seated
	1.5	4,000 (1,800)	5,000 (2,250)	6,000 (2,700)	6,500 (2,950)	8,000 (3,629)
	1.6	24 (610)	24 (610)	24 (610)	24 (610)	24 (610)
	1.8	16.3 (415)	16.3 (415)	16.5 (420)	16.5 (420)	17.6 (447)
	1.9	56.3 (1,430)	56.3 (1,430)	56.3 (1,430)	56.3 (1,430)	61.8 (1,570)
	Weight	2.1	7,400 (3,365)	8,200 (3,715)	9,300 (4,225)	9,750 (4,430)
2.2		9,920/1,480 (4,495/670)	11,450/1,750 (5,185/780)	13,350/1,950 (6,045/880)	14,110/2,140 (6,410/970)	18,043/3,427 (8,184/1,554)
2.3		3,100/4,300 (1,405/1,960)	2,930/5,270 (1,325/2,390)	3,080/6,220 (1,400/2,825)	2,940/6,810 (1,335/3,095)	4,657/8,813 (2,112/3,997)
Tires	3.1	C	C	C	C	C
	3.2	21x7-15	21x7-15	21x8-15	21x8-15	22 x 9 x16
	3.3	16x5-10.5	16x5-10.5	16x6-10.5	16x6-10.5	18 x 7 x 12.2
	3.5	2/2	2/2	2/2	2/2	2/2
	3.6	34.9 (887)	35.9 (912)	35.9 (912)	35.7 (907)	41.0 (1,042)
	3.7	36.0 (915)	36.0 (915)	36.0 (915)	35.0 (890)	41.1 (1,044)
	Dimensions	4.1	6/8	6/8	6/8	6/8
4.2		83.9 (2,130)	83.9 (2,130)	83.9 (2,130)	83.9 (2,130)	84.1 (2,135)
4.3		5.8 (147)	5.8 (147)	6.0 (152)	6.0 (152)	6.3 (160)
4.4		127.0 (3,230)	127 (3,230)	127 (3,230)	127 (3,230)	113.4 (2,880)
4.5		176.4 (4,480)	176.4 (4,480)	176.4 (4,480)	176.4 (4,480)	162.0 (4,115)
4.7		83.6 (2,125)	83.6 (2,125)	83.6 (2,125)	83.6 (2,125)	84.8 (2,155)
4.8		43.0 (1,095)	43.0 (1,095)	43.0 (1,095)	43.0 (1,095)	43.5 (1,105)
4.19		130.9 (3,325)	133.1 (3,380)	135.4 (3,440)	136.8 (3,475)	162.2 (4,120)
4.20		89.6 (2,275)	91.7 (2,330)	94.1 (2,390)	95.5 (2,425)	102.0 (2,590)
4.21		41.9 (1,065)	41.9 (1,065)	43.7 (1,110)	43.7 (1,110)	50.0 (1,270)
4.22		1.6x3.9x41.3 (40x100x1,050)	1.6x3.9x41.3 (40x100x1,050)	1.8x4.9x41.3 (45x125x1,050)	1.8x4.9x41.3 (45x125x1,050)	2.0x5.9x47.2 (50x150x1,200)
4.23		II/A	II/A	III/A	III/A	III/A
4.24		38.3 (973)	38.3 (973)	40.35 (1,025)	40.35 (1,025)	44.6 (1,132)
4.31		4.33 (110)	4.33 (110)	4.33 (110)	4.33 (110)	4.3 (110.5)
4.32		5.31 (135)	5.31 (135)	5.31 (135)	5.31 (135)	5.1 (130)
4.34.1		142.3 (3,615)	144.3 (3,665)	146.5 (3,720)	147.6 (3,750)	163.9 (4,164)
4.35	76.2 (1,935)	78 (1,980)	80.3 (2,040)	81.5 (2,070)	90.5 (2,298)	
4.36	25.4 (644)	25.4 (644)	25.4 (644)	25.4 (644)	29.5 (750)	
Performance Data	5.1	10.6/10.9 (17/17.5)	10.6/10.9 (17/17.5)	10.3/10.9 (16.5/17.5)	10.3/10.9 (16.5/17.5)	10.2/10.5 (16.4/16.9)
	5.2	124/128 (0.63/0.65)	122/128 (0.62/0.65)	120/128 (0.61/0.65)	118/128 (0.60/0.65)	120.1/126.0 (0.61/0.64)
	5.3	100.4/90.5 (0.51/0.46)	100.4/90.5 (0.51/0.46)	100.4/90.5 (0.51/0.46)	100.4/90.5 (0.51/0.46)	100.4/88.6 (0.51/0.45)
	5.5	4,760/3,880 (17,540/17,250)	3,950/3,920 (17,540/17,410)	4,100/4,010 (18,230/17,850)	3,920/3,870 (17,440/17,220)	7,181/7,209 (31,987/32,115)
	5.6	4,400/4,300 (19,580/19,130)	4,410/4,350 (19,610/19,330)	4,620/4,470 (20,520/19,880)	4,420/4,300 (19,630/19,130)	7,154/8,224 (31,870/36,632)
	5.7	33.0/54.4	28.0/48.6	25.5/43.5	22.0/39.1	36.0/64.0
	5.8	37.5/62.3	30.4/53.3	28.8/49.6	24.8/44.2	42.0/77.0
	5.10	Foot/Hydraulic	Foot/Hydraulic	Foot/Hydraulic	Foot/Hydraulic	Foot/Hydraulic
Combustion Engine	7.1	GCT/K25	GCT/K25	GCT/K25	GCT/K25	PSI/4X 4.3L
	7.2	59.0 (44.0)	59.0 (44.0)	59.0 (44.0)	59.0 (44.0)	94.0 (70.0)
	7.3	2,600	2,600	2,600	2,600	2500
	7.3.1	132.9@1,600 (180.2)@1,600	132.9@1,600 (180.2)@1,600	132.9@1,600 (180.2)@1,600	132.9@1,600 (180.2)@1,600	209.4@1,800 (284)@1,800
	7.4	4/2,488	4/2,488	4/2,488	4/2,488	6/4,294
	7.10	12/50	12/50	12/50	12/50	12/75
Oth.	10.1	2,260 (156)	2,260 (156)	2,260 (156)	2,260 (156)	2,030 (140)
	10.2	15.9 (60)	15.9 (60)	15.9 (60)	15.9 (60)	31.7 (120)

Characteristics	1.1	Doosan	Doosan	Doosan	Doosan	Doosan
	1.2	<b>GC35S-9 BCS</b>	<b>GC45S-9</b>	<b>GC45S-9 BCS</b>	<b>GC55C-9</b>	<b>GC55C-9 BCS</b>
	1.3	LP	LP	LP	LP	LP
	1.4	Seated	Seated	Seated	Seated	Seated
	1.5	8,000 (3,629)	10,000 (4,536)	10,000 (4,536)	12,000 (5,443)	12,000 (5,443)
	1.6	24 (610)	24 (610)	24 (610)	24 (610)	24 (610)
	1.8	17.6 (447)	18.0 (457)	17.6 (447)	18.0 (457)	18.0 (457)
	1.9	61.8 (1,570)	70.5 (1,790)	61.8 (1,570)	70.5 (1,790)	70.5 (1,790)
	Weight	2.1	12,808 (5,810)	15,754 (7,146)	14,658 (6,649)	16,702 (7,576)
2.2		18,378/2,430 8,336/1,102)	20,830/4,924 (9,448/2,234)	21,744/2,914 (9,863/1,322)	23,948/4,753 (10,863/2,156)	24,257/4,083 (11,003/1,852)
2.3		4,992/7,816 (2,264/3,545)	4,869/10,885 (2,208/4,937)	4,884/9,774 (2,215/4,433)	4,795/11,906 (2,175/5,401)	5,104/11,236 (2,315/5,097)
Tires	3.1	C	C	C	C	C
	3.2	22 x 9 x 16	22 x 12 x 16	22 x 12 x 16	22 x 12 x 16	22 x 12 x 16
	3.3	18 x 7 x 12.2	18 x 8 x 12.2	18 x 8 x 12.2	18 x 8 x 12.2	18 x 8 x 12.2
	3.5	2/2	2/ 2	2/ 2	2/ 2	2/ 2
	3.6	41.0 (1,042)	43.9 (1,116)	43.9 (1,116)	43.9 (1,116)	43.9 (1,116)
	3.7	41.1 (1,044)	41.1 (1,044)	41.1 (1,044)	41.1 (1,044)	41.1 (1,044)
	Dimensions	4.1	5/6	5/6	5/6	5/6
4.2		84.1 (2,135)	86.0 (2,185)	86.0 (2,185)	86.0 (2,185)	86.0 (2,185)
4.3		6.3 (160)	6.3 (160)	6.3 (160)	6.3 (160)	6.3 (160)
4.4		113.4 (2,880)	113.4 (2,880)	113.4 (2,880)	103.5 (2,630)	103.5 (2,630)
4.5		162.0 (4,115)	169.9 (4,315)	169.9 (4,315)	160.0 (4,065)	160.0 (4,065)
4.7		84.8 (2,155)	84.8 (2,155)	84.8 (2,155)	84.8 (2,155)	84.8 (2,155)
4.8		43.5 (1,105)	43.5 (1,105)	43.5 (1,105)	43.5 (1,105)	43.5 (1,105)
4.19		162.2 (4,120)	162.2 (4,120)	162.2 (4,120)	162.2 (4,120)	162.2 (4,120)
4.20		97.6 (2,480)	105.9 (2,690)	101.3 (2,573)	108.3 (2,750)	104.5 (2,655)
4.21		50.0 (1,270)	55.9 (1,420)	55.9 (1,420)	55.9 (1,420)	55.9 (1,420)
4.22		2.0x5.9x47.2 (50x150x1,200)	2.4x5.9x47.2 (60x150x1,200)	2.4x5.9x47.2 (60x150x1,200)	2.4x5.9x47.2 (60x150x1,200)	2.4x5.9x47.2 (60x150x1,200)
4.23		III/A	IV/A	IV/A	IV/A	IV/A
4.24		44.6 (1,132)	50.8 (1,290)	50.8 (1,290)	50.8 (1,290)	50.8 (1,290)
4.31		4.3 (110.5)	4.3 (110.5)	4.3 (110.5)	4.3 (110.5)	4.3 (110.5)
4.32		5.1 (130)	5.1 (130)	5.1 (130)	5.1 (130)	5.1 (130)
4.34.1		148.3 (3,767)	160.6 (4,078)	153.7 (3,905)	162.8 (4,136)	160.4 (4,073)
4.35		82.8 (2,104)	95.1 (2,415)	87.9 (2,232)	97 (2,463)	94.5 (2,400)
4.36	29.5 (750)	29.5 (750)	29.5 (750)	29.5 (750)	29.5 (750)	
Performance Data	5.1	10.2/10.5 (16.4/16.9)	10.0/10.5 (16.1/16.9)	10.2/10.4 (16.4/16.8)	10.0/10.5 (16.0/16.9)	10.0/10.5 (16.1/16.9)
	5.3	120.1/126.0 (0.61/0.64)	116.1/126.0 (0.59/0.64)	116.1/126.0 (0.59/0.64)	110.2/126.0 (0.56/0.64)	110.2/126.0 (0.56/0.64)
	5.5	100.4/88.6 (0.51/0.45)	100.4/88.6 (0.51/0.45)	100.4/88.6 (0.51/0.45)	100.4/ 88.6 (0.51/0.45)	100.4/88.6 (0.51/0.45)
	5.6	7,198/7,227 (32,066/32,193)	7,016/7,143 (31,252/31,821)	7,152/7,181 (31,860/31,987)	6,939/7,117 (30,909/31,703)	6,948/7,128 (30,948/31,752)
	5.6	8,270/ 8,241 (36,838/36,711)	8,070/8,153 (35,946/36,319)	8,224/8,195 (36,632/36,505)	7,993/8,127 (35,603/36,201)	8,001/8,136 (35,643/36,240)
	5.7	38.0/69.0	29.0/51.0	34.0/56.0	25.0/47.0	25.0/49.0
	5.8	44.0/84.0	33.0/61.0	35.0/68.0	29.0/56.0	29.0/58.0
	5.10	Foot/Hydraulic	Foot/Hydraulic	Foot/Hydraulic	Foot/Hydraulic	Foot/Hydraulic
	Combustion Engine	7.1	PSI/4X 4.3L	PSI/4X 4.3L	PSI/4X 4.3L	PSI/4X 4.3L
7.2		94 (70)	94 (70)	94 (70)	94 (70)	94 (70)
7.3		2,500	2,500	2,500	2,500	2,500
7.3.1		209.4@1,800 (284.0)@1,800	209.4@1,800 (284.0)@1,800	209.4@1,800 (284.0)@1,800	209.4@1,800 (284.0)@1,800	209.4@1,800 (284.0)@1,800
7.4		6/4,294	6/4,294	6/4,294	6/4,294	6/4,294
7.10		12/75	12/75	12/75	12/75	12/75
Oth.	10.1	2,030 (140)	2,030 (140)	2,030 (140)	2,030 (140)	2,030 (140)
	10.2	31.7 (120)	31.7 (120)	31.7 (120)	31.7 (120)	31.7 (120)



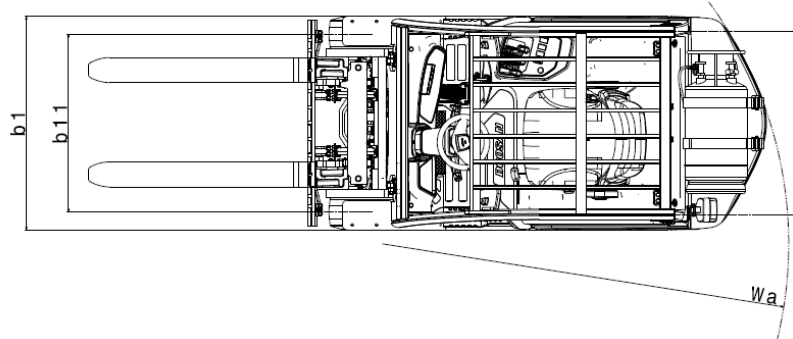
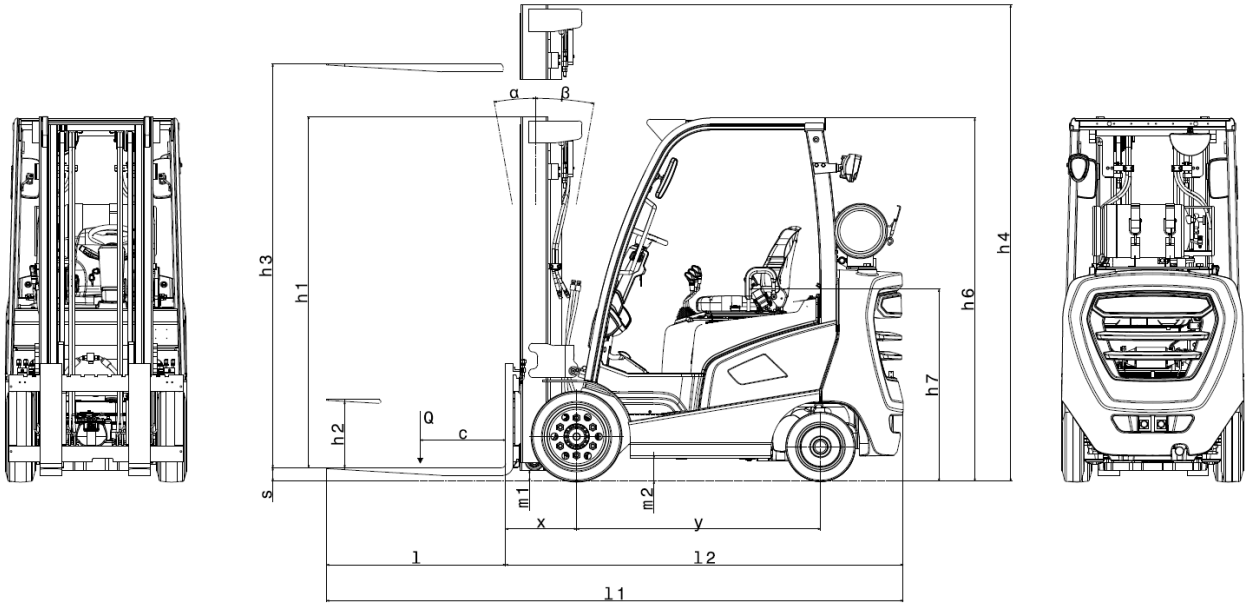

Doosan Industrial Vehicle America Corp.  
 Website: [www.doosanlift.com](http://www.doosanlift.com)

AUTHORIZED DEALER

GCS-9\_SPEC

2019 JAN